



**APPLICATIONS** Réfrigération, air climatisé, plomberie, électrique & communication

**INSTALLATION** Sans outils, style Tie-wrap

- MATÉRIAU**
- Nylon
  - Résistant aux rayons UV
  - Températures d'utilisation : -40° à 178°F (-40° to 81°C)
  - Surface non-adhésive permettant l'expansion linéaire de l'isolant thermique

**CERTIFICATION** Certifié UL aux USA (UL-723 / ASTM E 84) et répertorié ULC pour le Canada (ULC-S102.2)



**COULEUR**  GRIS ARGENT (G)

**Diamètre tuyau**

Diamètre boulon

	0.25" (6.3mm)	0.5" (12.7mm)	0.625" (15.9mm)	0.75" (19mm)	1" (25.4mm)	1.25" (31.8mm)	1.5" (38.1mm)	1.75" (44.5mm)	2" (50.8mm)	2.25" (57.2mm)
0.25" (6.3mm)	IMP050G	IMP050G	-	-	-	-	-	-	-	-
0.3125" (7.9mm)	IMP050G	IMP050G	IMP125G	IMP125G	IMP125G	IMP125G	-	-	-	-
0.375" (9.5mm)	IMP050G	IMP050G	IMP125G	IMP125G	IMP125G	IMP125G	IMP175G	-	-	-
0.5" (12.7mm)	IMP050G	IMP050G	IMP125G	IMP125G	IMP125G	IMP125G	IMP175G	IMP225G	IMP225G	-
0.688" (17.5mm)	IMP050G	IMP050G	IMP125G	IMP125G	IMP125G	IMP125G	IMP175G	IMP225G	IMP225G	IMP225G

# PIÈCE	A	B	C
IMP050G	0.5" (12.7mm)	5.62" (143mm)	0.68" (17mm)
IMP125G	0.5" (12.7mm)	5.77" (146.5mm)	1.25" (32mm)
IMP175G	0.5" (12.7mm)	6.20" (157.5mm)	1.75" (44.5mm)
IMP225G	0.5" (12.7mm)	6.20" (157.5mm)	1.71" (43.5mm)

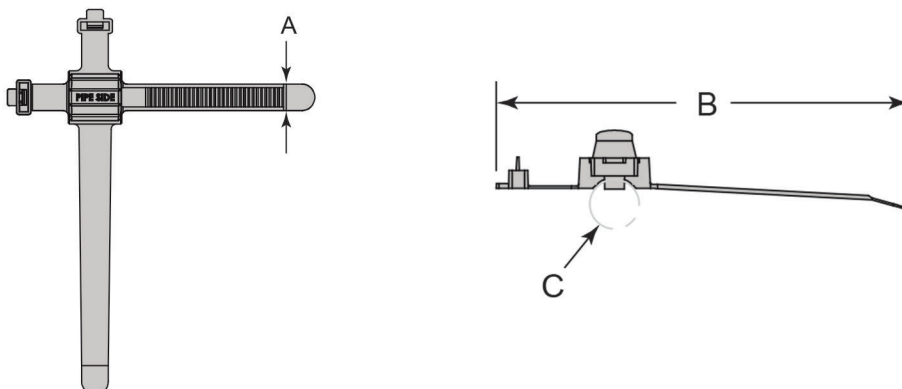

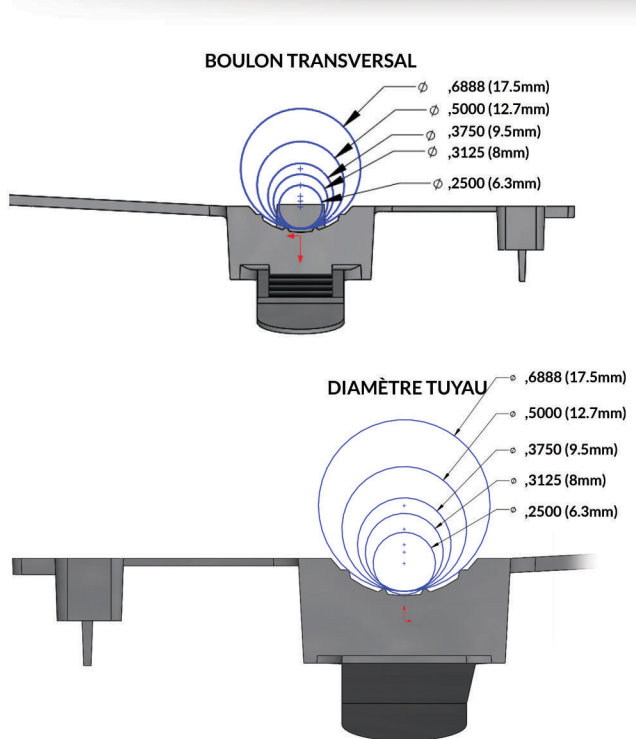

# PIÈCE	DIAMÈTRE TUYAU	DIAMÈTRE BOULON
IMP050G	0.25" - 0.688" (6.3mm à 17.5mm)	0.25" - 0.688" (6.3mm à 17.5mm)

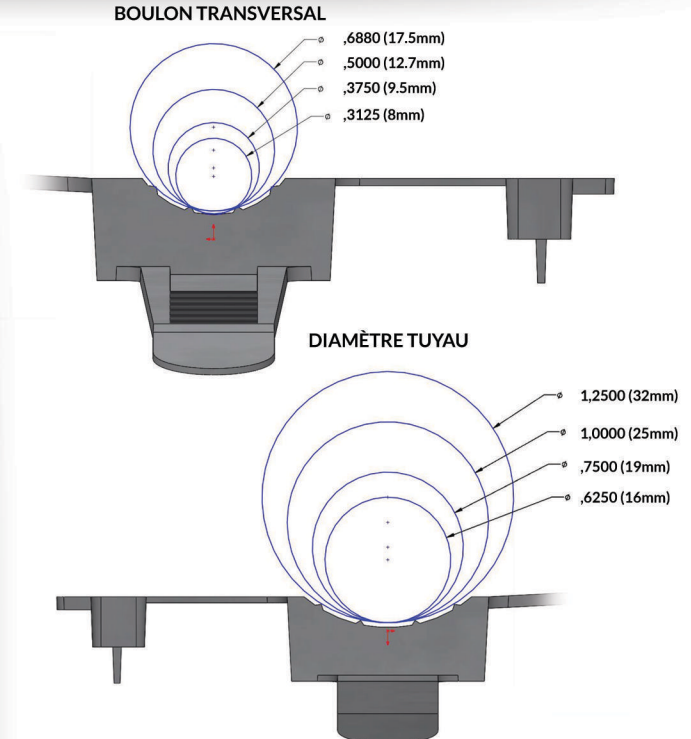

# PIÈCE	DIAMÈTRE TUYAU	DIAMÈTRE BOULON
IMP125G	0.625" - 1.25" (16mm à 32mm)	0.3125" - 0.688" (8mm à 17.5mm)

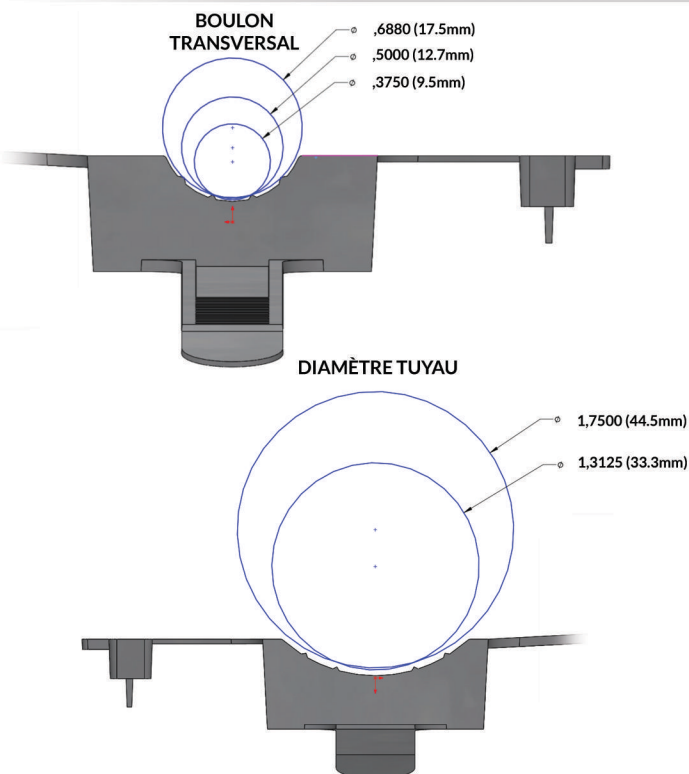

# PIÈCE	DIAMÈTRE TUYAU	DIAMÈTRE BOULON
IMP175G	1.3125" - 1.75" (33.3mm à 44.5mm)	0.375" - 0.688" (9.5mm to 17.5mm)

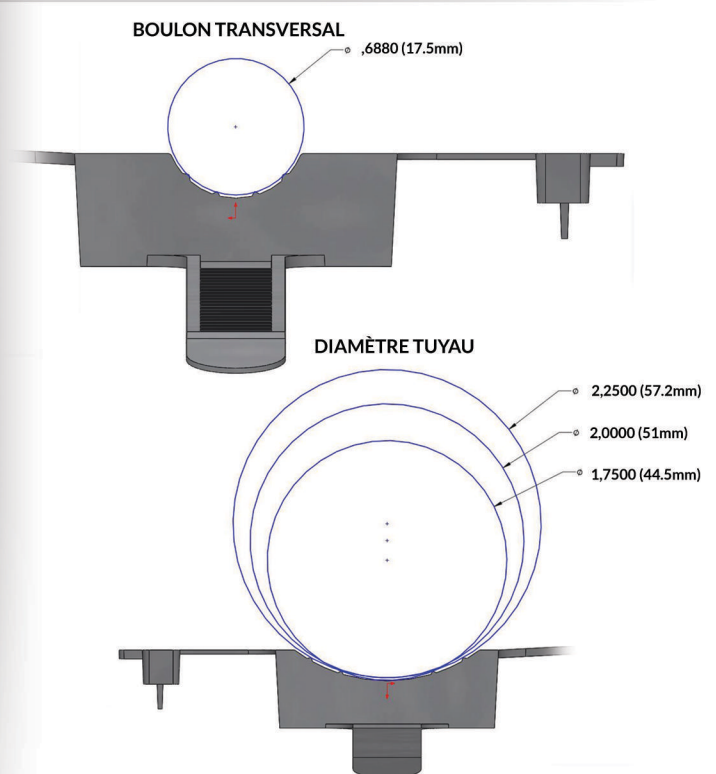

# PIÈCE	DIAMÈTRE TUYAU	DIAMÈTRE BOULON
IMP225G	1.75" - 2.25" (44.5mm à 57.2mm)	0.688" (17.5mm)